

Technical Information

Locking System 1401

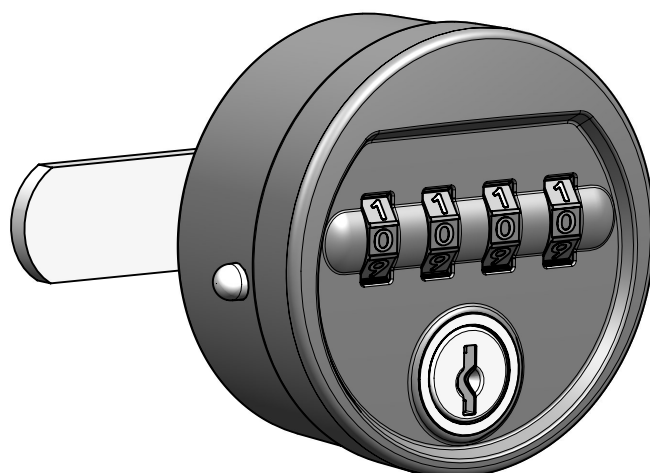

1.	<u>Product Description</u>	2
1.1	Main Features	2
1.2	General Information	2
2.	<u>Assembly Instructions</u>	3
2.1	Important Hints for Fitters	3
2.2	Assembly Exploded View	3
2.3	Fitting Dimensions and Tightening Torques	4
2.4	Lock Movements Setting	5
3.	<u>Operating Instructions for users</u>	6
3.1	Important Hints for Users	6
3.2	Lock Operation	6
3.3	Personal Code Setting / Changing	6
4.	<u>Operation Instructions for Administrators</u>	7
4.1	Important Hints for Administrators	7
4.2	Emergency Opening	7
4.3	QUICK-RESET	7
5.	<u>Ordering Information</u>	8
5.1	Important Basic Information	8
5.2	Order Matrix Cam	9
5.3	Order Matrix Lock / Service Key	10

1. Product Description 1401

1.1 Main Features

- Combination lock with 10.000 freely programmable user-codes
- Service cylinder with 200 different key numbers for emergency opening und resetting
- QUICK-RESET ¹ for an efficient administration
- ANTI-SPY ² -technology to protect the personal user-codes
- Automatic code-scrambling for even more safety and comfort
- Lock movement R / L settable
- Locking mechanism made of solid zinc die-cast
- Housing made of fibreglass-reinforced and easy to clean special plastic
- Retrofittable for most doors with standard fixing holes 16x19mm
- Lock fixing by nut (SW22)
- Cam fixing by screw (TX25)
- Comprehensive range of cams available with 2 and 3mm thickness
- Ideally suited for 1-point and 3-point cams

¹ Innovative function to restore to factory setting within seconds without time-consuming codefinding

² Innovative lock-system wherewith the readout and misuse of personal user-codes is no longer possible

For more informationen visit: wf-locks.com

1.2 General Information

- Please read carefully these instructions before fitting and first use
 - Do not expose lock to enviromental influences like water, moist, dust etc.
 - Lock operable within a temperature range from 0- 50°C (32°F to 120°F)
 - For cleaning use damp cloth and common houshold detergent
 - Don't use aggressive or chemical products
 - When cleaning avoid that water or detergend enters the lock
-

2. Assembly Instructions 1401

2.1 Important Hints for Fitters

- Use only the supplied original fixing elements
- The cam fixing screw is thread-forming and self-retaining
- Use only suitable and properly functioning tools
- Do not break the torque limits
- Lock movement must be set by the guide-washer before fixing the cam (see 2.4)
- The lock movement is 90°
- The 16x19 piercing hole must be vertical
- In locked position the code-wheels are horizontal aligned
- Observe the given tolerances

2.2 Assembly Exploded-View

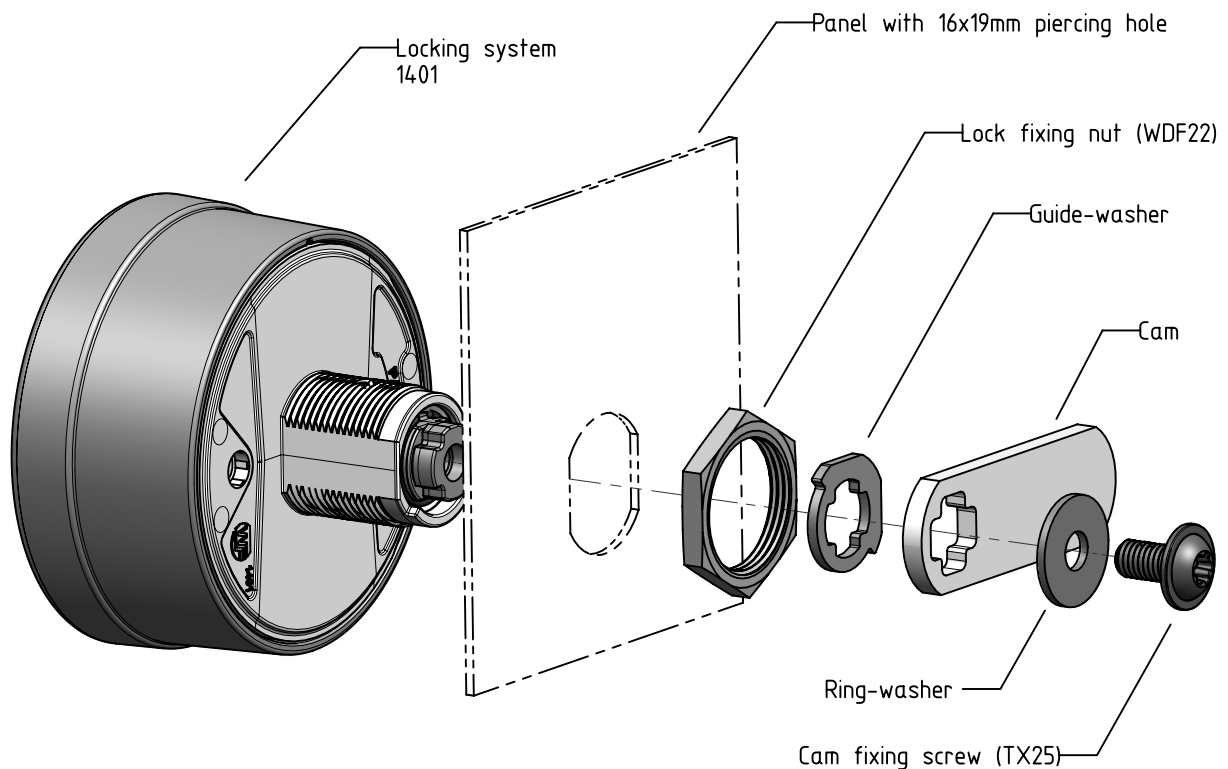

2. Assembly Instructions 1401

2.3 Fitting Dimensions and Tightening Torques

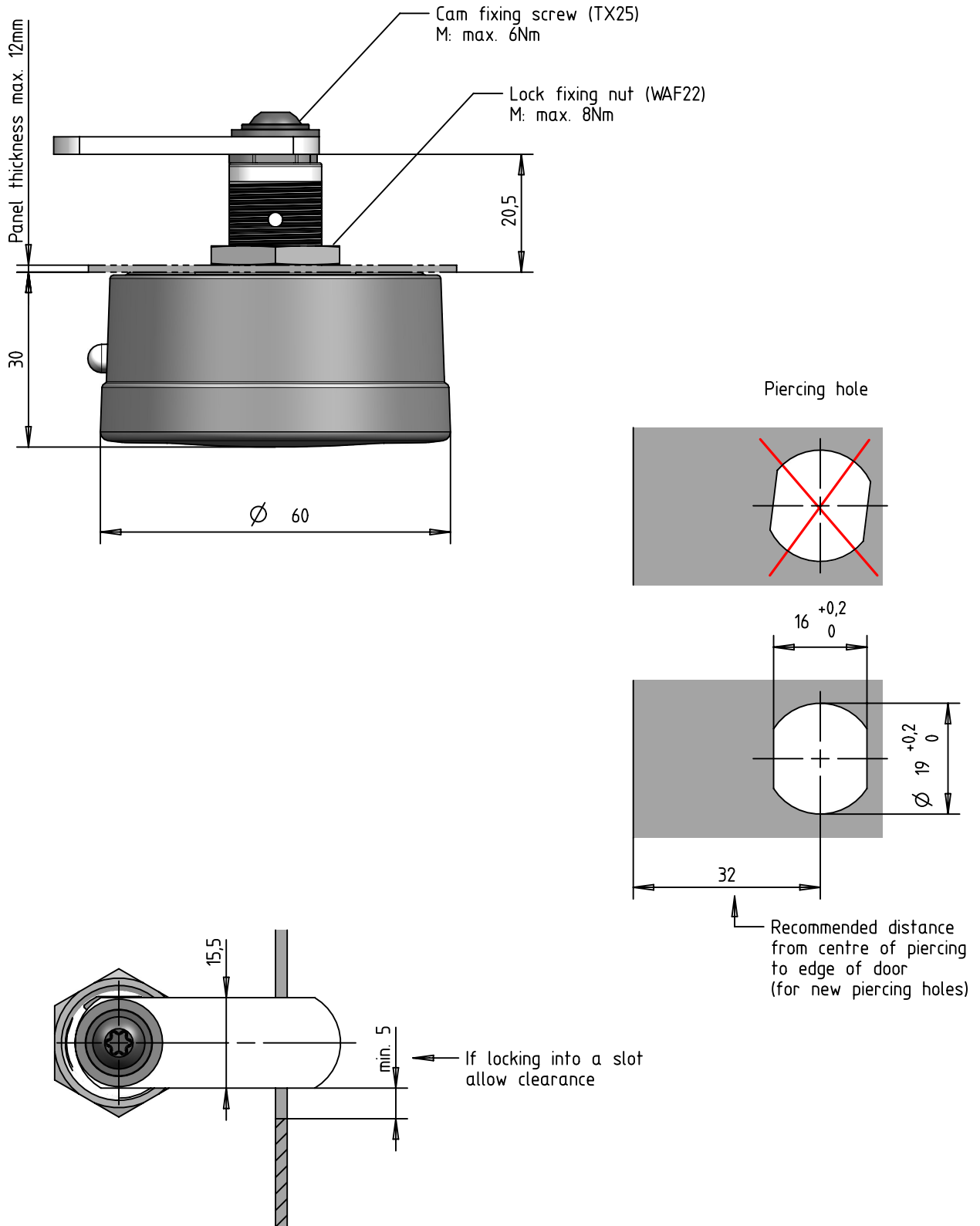

2. Assembly Instructions 1401

2.4 Lock Movement Setting

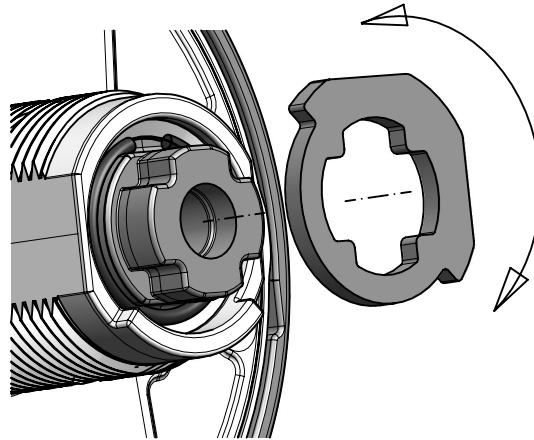

Orientation guide-washer
in locked position

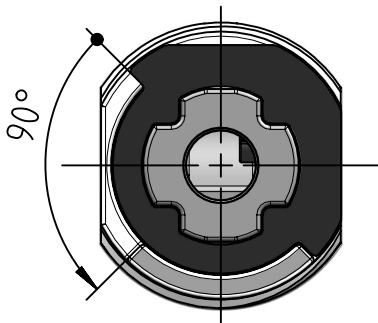

Lock movement to unlock

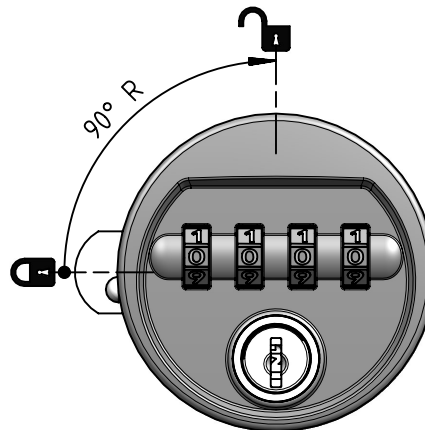

"R" for right-hinged doors

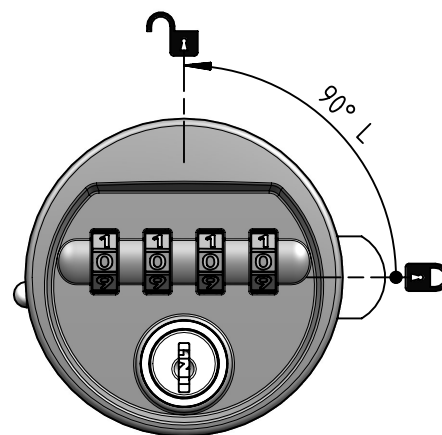
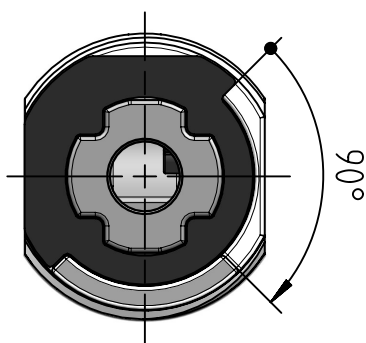

"L" for left-hinged doors

3. Operating Instructions for Users 1401

3.1 Important Hints for Users

- The factory setting code is 0-0-0-0
- Change factory setting code to your own personal code by all means
- Fix your code on your mind or note it down if needed
- You can change your personal code at any time
- For setting or changing the code lock must be horizontal
- For safety reasons the indicated code automatically scrambles to 0-0-0-0 while turning the lock to open
- To close the lock you don't need to enter your code again
- In case of lost code contact the administrator. He can reset the lock to factory setting, so that you can set a new code
- Take care that the cam moves freely and is not obstructed by objects in the locker

3.2 Lock Operation -----> open -----> close

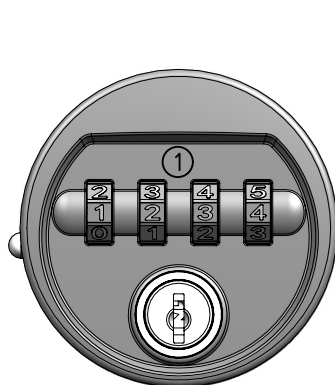

1. Enter personal code (if set)

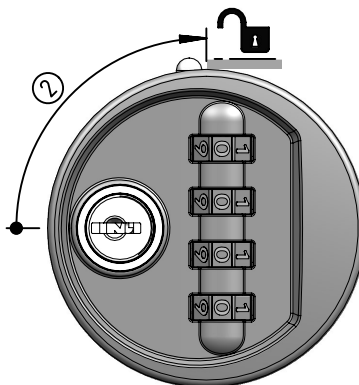

2. Turn lock until it stops (code scrambles to 0-0-0-0)

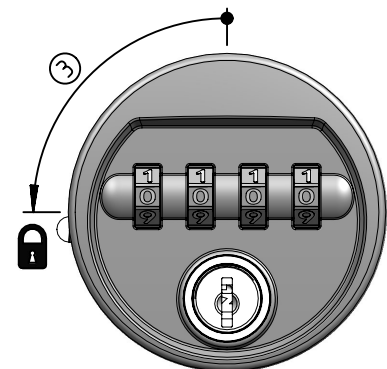

3. Turn lock back until it clicks into place

3.3 Personal Code Setting / Changing

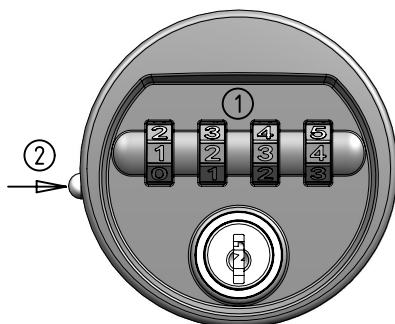

1. Enter personal code (if set) or default code 0-0-0-0 (first use)
2. Press coding button and hold it pressed

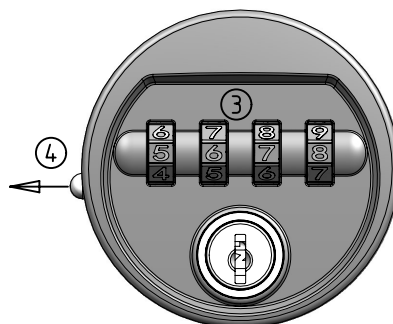

3. Enter new code
4. Release coding button (new code is set, memorise!)

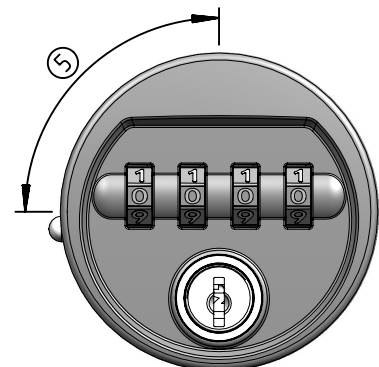

5. Turn lock open and close once (code scrambles to 0-0-0-0)

4. Operation Instructions for Administrators 1401 LOCKS

4.1 Important Hints for Administrators

- With service key you can always open and/or reset the lock without the need to find the valid code
- Choose the emergency opening if the set code shall be retained and the lock closed again afterwards
- Choose the QUICK-RESET if the set code shall be deleted and the lock reset to factory setting 0-0-0-0
- Service keys can only be removed in closed position
- Service keys are provided with key numbers (differs)
- For security reasons please keep the number of service keys at a minimum and keep it in a safe place

4.2 Emergency Opening

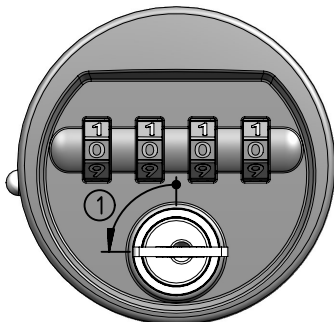

1. Insert service key into barrel and turn it 90° to the left

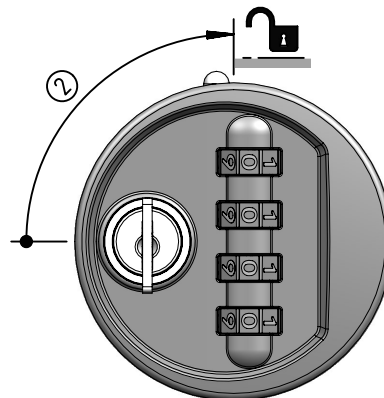

2. Turn lock to open position, without pressing the code button

4.3 QUICK-RESET

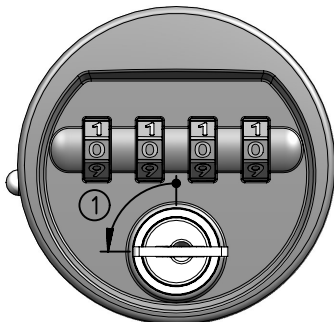

1. Insert service key into barrel and turn it 90° to the left

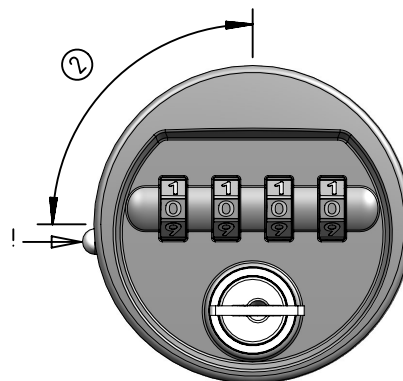

2. With pressed code button turn lock open and close once

5. Ordering Information 1401

5.1 Important Basic Information

Lock, cam and service key will be ordered separately. An complete order or inquiry comprises 3 order numbers:

1. Order no. cam	(order matrix 5.2)	ex.: C1401-3-4-20-30-DO
2. Order no. lock	(order matrix 5.3)	ex.: L1401-G-051-R-09-H
3. Order no. service key	(order matrix 5.3)	ex.: S1401-051

Cam and fixing elements are standardly delivered unmounted. On request the cam can be premounted as well. The needed specification for that will be done according to order matrix 5.2.

Important: If you want the cam premounted please make sure that the lock with fixed cam still fits through the 16x19 piercing hole. That mainly depends on the cam shape and the panel thickness.

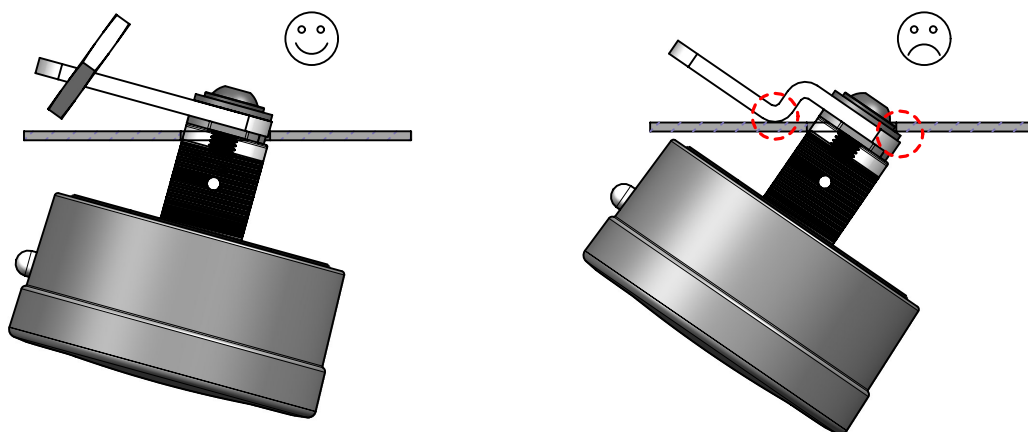

The factory-set code is 0-0-0-0.

For security reasons please keep the number of service keys at a minimum.

Service keys and locks are provided with key numbers. For security reasons the key number of the lock is on the back.

Each order quantity will be delivered keyed to pass. This means that all locks have the same key number (differ number), with one key opening all.

If you need different key numbers e.g. in order to equip different rooms or permissions please split the order quantity in different key numbers.

For the service cylinder please chose one of the standard key numbers according the order matrix 5.3. On request there are additional 200 key numbers available.

For short delivery times please prefer the given standards from the order matrices. But special designs such as differnt colours or something else can also be requested at any time.

5. Ordering Information 1401

5.2 Order Matrix Cam

1. Thickness "T"

T = 2mm / 3mm

2. Shape

3. Amount of crank "A"

A	mm	for shape
00	0	-1-2-
03	1,2	-3-5-6-
04	1,6	-3-5-6-
05	2,0	-3-5-6-
06	2,4	-3-5-6-
07	2,8	-3-5-6-
08	3,2	-3-5-6-
10	4,0	-3-5-6-
12	4,8	-3-4-5-6-7-8-
14	5,6	-3-4-5-6-7-8-
16	6,4	-4-7-8-9-
20	7,9	-4-7-8-9-
21	8,3	-3-5-6-
25	9,9	-3-4-5-6-7-8-9-
28	11,1	-4-7-8-9-
32	12,7	-3-4-5-6-7-8-9-
34	13,5	-4-7-8-9-
38	15,0	-4-7-8-9-
40	15,9	-4-7-8-9-
44	17,5	-4-7-8-9-
48	19,1	-4-7-8-9-
50	19,9	-4-7-8-9-
64	25,4	-4-7-8-9-
72	28,6	-4-7-8-9-

4. Length "B"

-Length "B" made to order
-Step range 1mm
-Length before bending max.100mm

5. Cam end

Order example cam:

C1401-3-4-20-38-DO

5. Ordering Information 1401

5.3 Order Matrix Lock / Service Key

