

**Mounting instruction:**

All bolts must be secured with Loctite 620 or equal.  
 Loctite 620 is only usable by temperatures lower than 220° C.  
 Otherwise other alternatives must be used.  
 Mounting examples see previous pages

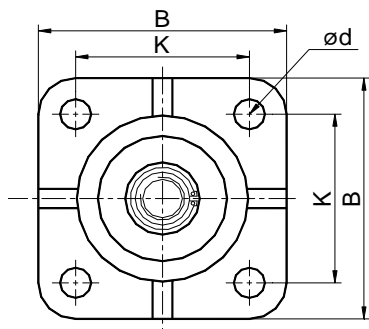

Bottom view

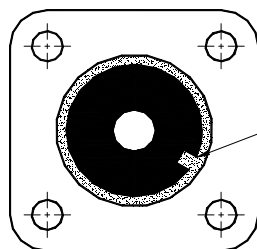

Align slot with hole in housing for using of fixing tool while tightening top bolt

**Dimensions:**

Type no.	Stock No.	øA	B	G	H	S	K	ød	Weight	Static load	Max. dyn. load	
		[mm]	[mm]		[mm]	[mm]	[mm]	[mm]			[kg]	[daN]
<b>F 1212</b>	12000-01-0012	35	80	M12	50	6	64	8,2	0,67	50 - 250	500	500
<b>F 1216</b>	12000-01-0016	52	100	M16	70	8	70	12,5	1,43	50 - 900	3500	3500
<b>F 1218</b>	12000-01-0018	60	130	M16	85	10	100	13,5	3,00	250 - 1500	6000	6000
<b>F 1220</b>	12000-01-0020	100	200	M20	100	10	152	17,0	9,20	500 - 2500	12500	12500
<b>F 1227</b>	12000-01-0027	100	220	M27	103	10	170	17,0	19,70	500 - 7000	22500	22500

**Flexible fix point supports**

**All-metal type**

**Stock no. 12000**

**Description:**

- Mounting of flat design
- High static load capacity
- High dynamic load capacity
- High stability
- Resonant frequency: 15-20 Hz

See also

**Technical information**  
**Mounting examples**

**Material:**

Housing:  
 Cast iron, black painted  
 All-metal cushion:  
 Stainless steel wire

