

DYNAPAC

Part of the Atlas Copco Group

LG500 (Hatz)

Forward & reversible plates



Technical data

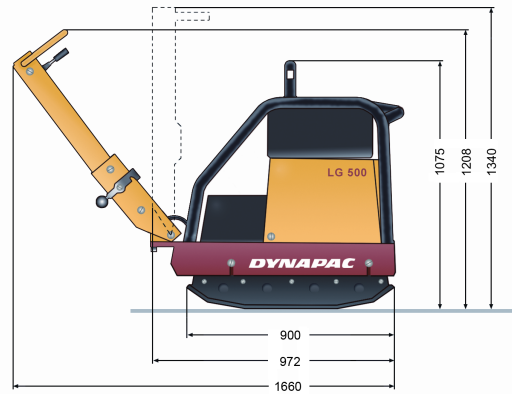
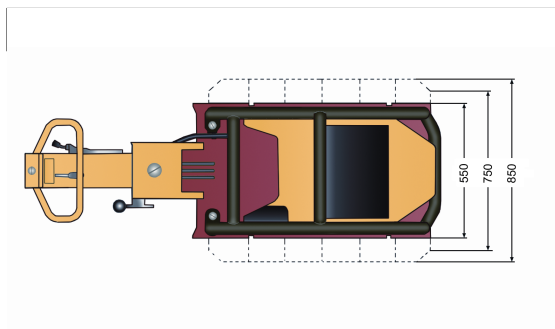

Dimensions		LG500 (Hatz)
Plate width		550 mm
Plate length		990 mm
Length		1,660 mm
Height		1,340 mm
Masses		
Net mass		478 kg
Operating mass (CE)		481 kg
Compaction		
Vibration frequency		60 Hz
Nominal amplitude		2.10 mm
Centrifugal force		60 kN
Traction		
Speed		24 m/ min
Engine		
Manufacturer		Hatz
Type		Supra 1D81Z
Fuel		Diesel
Rated power		8.20 kW
Rated power @		2,270 rpm
Rated power (rating standard)		SAE J1995

Find your local dealer at www.dynapac.com

We reserve the right to change specifications without notice. Photos and illustrations do not always show standard versions of machines. The above information is a general description only, all informations are supplied without liability.