

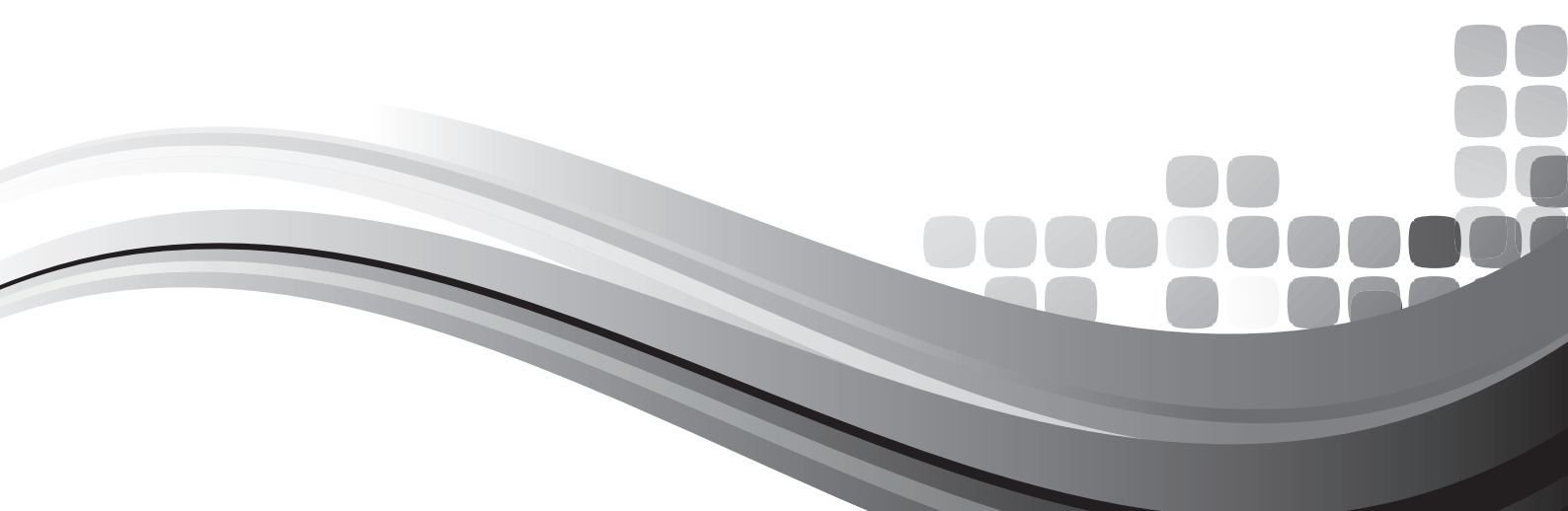

## INSTALLATION AND OPERATION MANUAL

# AMC+ SERIES

MIXER AMPLIFIERS    AMC+30  
                                  AMC+60  
                                  AMC+120  
                                  AMC+250



## IMPORTANT SAFETY INFORMATION

1. Read these instructions.
2. Keep these instructions.
3. Heed all warnings.
4. Follow all instructions.
5. Do not use this apparatus near water.
6. Clean only with dry cloth.
7. Do not block any ventilation openings. Install in accordance with the manufacturer's instructions.
8. Do not install near any heat sources such as radiators, heat registers, stoves, or other apparatus (including amplifiers) that produce heat.
9. Do not defeat the safety purpose of the polarized or grounding-type plug. A polarized plug has two blades with one wider than the other. A grounding type plug has two blades and a third grounding prong. The wide blade or the third prong are provided for your safety. If the provided plug does not fit into your outlet, consult an electrician for replacement of the obsolete outlet.
10. Protect the power cord from being walked on or pinched particularly at plugs, convenience receptacles, and the point where they exit from the apparatus.
11. Only use attachments/accessories specified by the manufacturer.
12. Use only with the cart, stand, tripod, bracket, or table specified by the manufacturer, or sold with the apparatus. When a cart is used, use caution when moving the cart/apparatus combination to avoid injury from tip-over.
13. Unplug this apparatus during lightning storms or when unused for long periods of time.
14. Refer all servicing to qualified service personnel. Servicing is required when the apparatus has been damaged in any way, such as power-supply cord or plug is damaged, liquid has been spilled or objects have fallen into the apparatus, the apparatus has been exposed to rain or moisture, does not operate normally, or has been dropped.
15. This appliance shall not be exposed to dripping or splashing water and that no object filled with liquid such as vases shall be placed on the apparatus.
16. Plug this apparatus to the proper wall outlet and make the plug to be disconnected readily operable.
17. Mains plug is used as disconnected device and it should remain readily operable during intended use. In order to disconnect the apparatus from the mains completely, the mains plug should be disconnected from the mains socket outlet completely.
18. **WARNING:** To reduce the risk of fire or electric shock, do not expose this apparatus to rain or moisture.
19. An appliance with a protective earth terminal should be connected to a mains outlet with a protective earth connection.
20. AMC+30 - Risk of hazardous energy. Class 2 wiring should be used.
21. AMC+60, AMC+120, AMC+250 - Risk of hazardous voltage. Class 3 wiring should be used.
22. The apparatus should be disconnected from the mains completely before speaker wiring. The speaker output should be properly protected from direct contact and pay attention to speaker connections, terminals and speaker wiring during normal operation.



 To indicate hazards arising from dangerous voltages.

## PRÉCAUTIONS DURANT UTILISATION

1. LISEZ ces instructions.
2. Tenez ces instructions.
3. Notez tous les avertissements.
4. Suivez toutes les avertissements.
5. N'utilisez pas ce produit près de l'eau (la piscine, la plage, le lac, etc.).
6. Nettoyez seulement avec une étoffe sèche.
7. Ne bloquez aucuns trous de ventilation. Installez en accord avec les instructions du fabricant.
8. N'installez près aucunes sources de chaleur comme radiateurs, registres de chaleur, fours ou les autres équipements (y compris amplificateurs) qui produisent la chaleur.
9. Ne défaites pas le but de sécurité de la fiche polarisée ou base-type. Une fiche polarisée a deux tranchants avec un plus large que l'autre. Une fiche de base type a deux tranchants et une troisième pointe de base, le tranchant large ou la troisième pointe est fourni pour votre sécurité. Si la fiche donnée ne conforme pas votre prise de contact, consultez un électricien pour remplacement de la prise de contact obsolète.
10. Protégez le cordon de secteur contre être marchée dessus ou pincez en particulier aux fiches, aux douilles de convenance, et au point où ils sortent de l'appareil.
11. Seulement utilisez attachements/accessoires spécifiés par le fabricant.
12. Utilisez seulement avec un chariot, un stand, un trépied, un support ou une table indiquée par le fabricant, ou vendue avec l'appareil. Quand un chariot est utilisé, faites attention en déplaçant la combinaison d'appareil/chariot pour éviter de se déséquilibrer.
13. Arrachez la fiche du dispositif durant éclair et orage ou quand pas utilisé pour longues périodes de temps.
14. Référez au personnel qualifié de service pour toutes réparations. La réparation est donnée quand le système a été endommagé à n'importe façon, par exemple un fil ou une fiche endommagé(e) de la source d'alimentation. Avoir été exposé à pluie ou humidité, n'opère pas normalement, ou avoir été tombé.
15. L'appareil ne doit pas être exposé aux écoulements ou aux éclaboussures et aucun objet ne contenant de liquide, tel qu'un vase, ne doit être placé sur l'objet.
16. Branchez l'appareil à une source appropriée et faire que la prise à débrancher soit facilement accessible.
17. La prise du secteur ne doit pas être obstruée ou doit être facilement accessible pendant son utilisation. Pour être complètement déconnecté de l'alimentation d'entrée, la prise doit être débranchée du secteur.
18. **AVERTISSEMENT:** Pour éviter le risque d'incendie ou de chocs électriques, ne pas exposer cet appareil à la pluie ou à l'humidité.
19. Un appareil avec la borne de terre de protection doit être connecté au secteur avec la connexion de terre de protection.
20. AMC+30 - Danger d'électrocution. Afin d'assurer un bon fonctionnement utiliser un câble de catégorie 2.
21. AMC+60, AMC+120, AMC+250 - Danger de voltage. Afin d'assurer un bon fonctionnement utiliser un câble de catégorie 3.
22. Assurez-vous que l'appareil est hors tension avant de connecter les hauts parleurs. Vérifiez que la sortie des enceintes soit protégées contre un contact physique. Respecter les polarités des terminaux ainsi que le câblage des enceintes pendant le fonctionnement afin d'assurer une utilisation sécurisée.



 Pour indiquer les risques résultant de tensions dangereuses.



## AMC+ SERIES

The Australian Monitor AMC+ series of amplifiers takes the heritage and reliability of our famous AMIS series amplifiers and integrates these features into low cost amplifiers for applications where reliability is everything, but the more elaborate features of our AMIS series are not required.

Available in 30, 60, 120 and 250 watt versions, the AMC+ series are 2 RU mixer amplifiers, featuring 70/100 volt line and 4 ohm outputs, and 4 universal mic/line inputs.

Master volume and overall treble and bass controls are provided, along with Vox triggered muting (defeatable), giving channel 1 priority over inputs 2, 3 and 4. There is also the facility to add a tone generator card.

The Australian Monitor AMC+ series gives the contractor a low cost alternative in applications that are price sensitive, but still require a high quality of sound reproduction and reliability.

INTRODUCTION	3
FRONT PANEL	4
REAR PANEL	5
INSTALLATION	6
TROUBLESHOOTING	8
BLOCK DIAGRAM	9
FUNCTIONAL NOTES & INTERNAL ADJUSTMENTS	10
DIMENSIONS	11
SPECIFICATIONS	12
NOTES	14

Revision 1.9 September 2011

## WARNING!

TO PREVENT FIRE OR SHOCK HAZARD, DO NOT USE THE PLUG WITH AN EXTENSION CORD, RECEPTACLE OR OTHER OUTLET UNLESS THE BLADES CAN BE FULLY INSERTED TO PREVENT BLADE EXPOSURE.

TO REDUCE THE RISK OF FIRE OR ELECTRIC SHOCK, DO NOT EXPOSE THIS APPLIANCE TO RAIN OR MOISTURE.

TO PREVENT ELECTRICAL SHOCK, MATCH WIDE BLADE PLUG TO WIDE SLOT & FULLY INSERT.

## CAUTION

THESE SERVICING INSTRUCTIONS ARE FOR USE BY QUALIFIED SERVICE PERSONNEL ONLY. TO REDUCE THE RISK OF ELECTRIC SHOCK DO NOT PERFORM ANY SERVICING OTHER THAN THAT CONTAINED IN THE OPERATING INSTRUCTIONS UNLESS YOU ARE QUALIFIED TO DO SO.



The lightning flash with arrowhead symbol, within an equilateral triangle, is intended to alert the user to the presence of uninsulated "dangerous voltage" within the product's enclosure that may be of sufficient magnitude to constitute a risk of electric shock to persons.

### CAUTION

**RISK OF ELECTRIC SHOCK  
DO NOT OPEN**

**WARNING:** TO REDUCE THE RISK OF ELECTRIC SHOCK, DO NOT REMOVE COVER (OR BACK). NO USER SERVICEABLE PARTS INSIDE. REFER SERVICING TO QUALIFIED SERVICE PERSONNEL.



The exclamation point within an equilateral triangle is intended to alert the user to the presence of important operating and maintenance (servicing) instructions in the literature accompanying the appliance.

Rating plate and caution marking are marked on the back enclosure of the apparatus



## FRONT PANEL

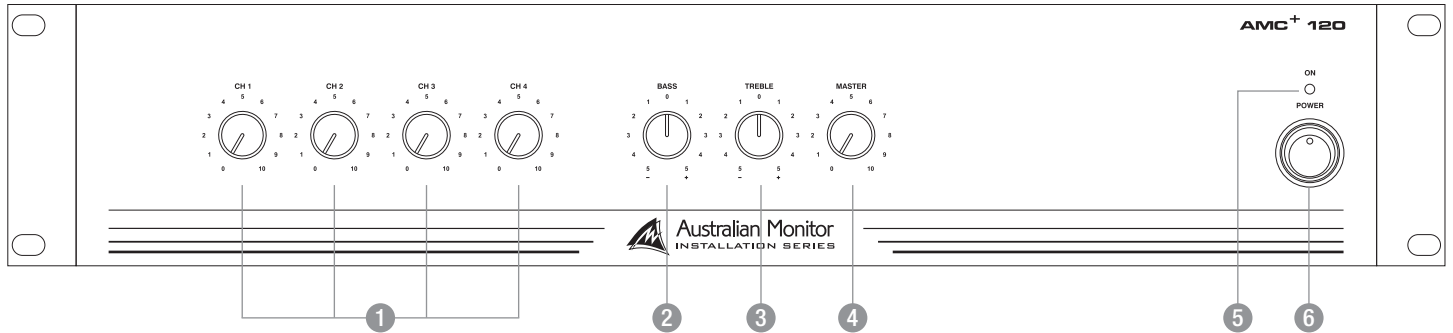

### 1 CH 1-4

These control the levels for each channel input.

### 2 Bass

There is 12dB of cut and boost at 100Hz.

### 3 Treble

There is 9dB of cut and boost at 10kHz.

### 4 Master

This controls the overall mixed output level.

### 5 On

This LED indicates the unit is powered "on".

### 6 Power

This switch switches power on or off the mains. The up position is on.

#### NOTE:

##### For the model AMC+30

 Risk of hazardous energy. Class 2 wiring should be used. The apparatus should be disconnected from the mains completely before speaker wiring. The speaker output should be properly protected from direct contact and pay attention to speaker connections, terminals and speaker wiring during normal operation.

##### For the model AMC+60, AMC+120, AMC+250

 Risk of hazardous voltage. Class 3 wiring should be used. The apparatus should be disconnected from the mains completely before speaker wiring. The speaker output should be properly protected from direct contact and pay attention to speaker connections, terminals and speaker wiring during normal operation.



This terminal is hazardous live and that external wiring connected to these terminals requires installation by an instructed person.

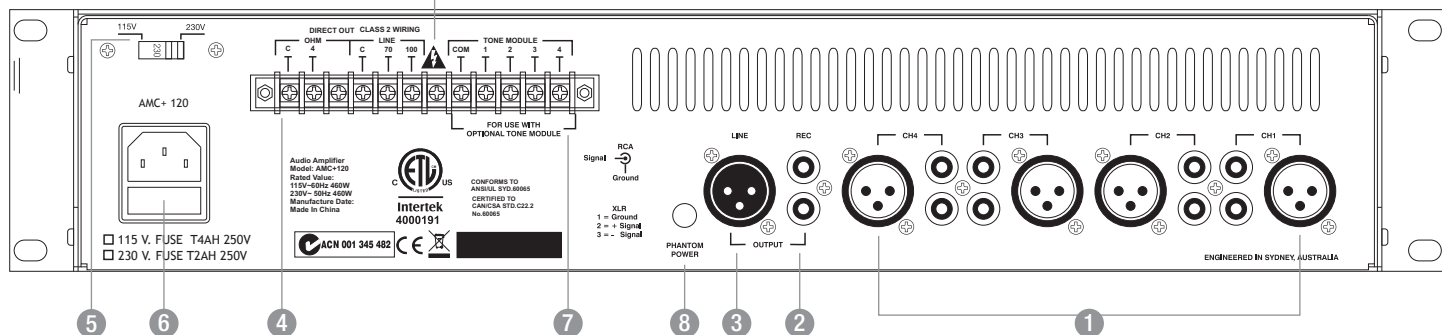

**1 CH 1-4**

Each channel input section has two inputs: XLR input – This is a balanced microphone input. It has an input sensitivity of 1mV. RCA input – This is an unbalanced line level input. It has an input sensitivity of 150mV. The two RCA sockets are summed to mono internally.

**2 REC Output**

The REC output is on unbalanced RCA connectors. The output level is 150mV into 10kohm at rated output. The output is dual mono. The REC output is not affected by the MASTER volume control or the BASS and TREBLE controls. The REC output does not receive the tone signal if the optional tone generator module is installed.

**3 Line Output**

The LINE output is on a balanced XLR connector. The output level is 0.775V into 1k at rated output.

**Note:** When wiring the LINE output as unbalanced, Pin2 should be wired as hot and Pin1 should be wired as ground/shield. Do not wire Pin3.

**4 Direct Out**

Speaker connections are provided on screw terminals. 4 ohm low impedance, 70V and 100V line outputs are provided.

**5 Mains Voltage Selector**

The operating voltage of the amplifier is user selectable between for 115V or 230V operation via a slide switch located above the AC mains inlet. This switch should be set to match the AC voltage of your country.

**!** Failure to set the Mains Voltage Selector correctly prior to use will result in catastrophic failure.

**Minimum Impedance**

	AMC+30	AMC+60	AMC+120	AMC+250
<b>Distributed Line Output</b>				
70V	166ohm	83ohm	41ohm	20ohm
100V	333ohm	166ohm	83ohm	40ohm
<b>Low Impedance Output</b>				
	4ohm	4ohm	4ohm	4ohm

**Note:** Only connect one output – either Distributed Line or Low Impedance per channel. Do not connect LowZ and 70/100V at the same time.

The output strip comes fitted with a touch-proof cover held in place by two M3 machine screws with flat and spring washers.

**6 IEC Mains Input Socket**

This is a standard IEC 3 pin socket. It accepts a standard IEC mains cable, provided. The fuse draw at 5 contains the mains fuse and a spare. The mains fuse is a time lag (slow blow) HRC 20mm x 5mm ceramic type fuse.

The ratings are:	AMC+30	AMC+60	AMC+120	AMC+250
230V operation	0.5A	1.6A	2A	4A
115V operation	1A	3.15A	4A	8A

**!** Always replace the fuse with one of the same value and type.

**⚡** Always disconnect power to the amplifier before replacing fuses.

**7 (Optional) Tone Module**

These terminals are for use with an optional tone module (not supplied). Use Australian Monitor ATC5488 module.

**8 Phantom Power**

12V phantom power is available for condenser or electret microphones on the XLR input when this switch is pushed in.



# INSTALLATION

**NOTE:** Only connect one output – either Distributed Line or Low Impedance

## Mounting

Your amplifier is designed for standard 19" rack mounting and occupies 2 EIA rackunits (3.5").

The mounting centres are:

Vertical: 3.0" (76.2mm) Horizontal: 18.2" (461.2mm) to 18.7" (473.8mm)

The slots in the mounting flange will accept bolt diameters up to 1/4" (6.35mm). We recommend that you provide additional support for the amplifier, especially if road use is planned, as the weight could bend some rack frames. This support can be provided by secure shelving on support rails.

When rack mounting, it is advisable to allow 1 rack space above and below the amplifier. When multiple amplifiers are mounted in a rack, exhaust fans should be used on the rack.

Airflow for cooling the AMC30, AMC60 and AMC120 is by convection from bottom to top. Airflow for cooling the AMC250 is by fan from front to side.

Disconnect all cables and power sources from the amplifier before mounting in the rack.

Mount the amplifier so that hazardous conditions are not achieved due to uneven mechanical loading.

Position the amplifier in the mounting rack so that the four slots in the mounting ears are aligned with the rack mounting holes. Fasten the amplifier using four screws to suit the nuts/threads in the rack.

**REMARQUE:** Ne branchez une sortie - soit en ligne ou distribués basse impédance

## Montage

Cet ampli convient pour un montage en rack de 19" et a 2 unités de 3.5".

Les centres de montage sont:

Vertical: 3.0" soit 76.2 mm Horizontal: de 18.2" (soit 461.2mm) à 18.7" (soit 473.8 mm).

Vous pouvez mettre des vis de 6.5 mm maximum dans les fentes de la bride de montage. Nous vous recommandons un support supplémentaire car le poids peut parfois faire plier le châssis en cas d'usage intensif.

Lorsqu'un amplificateur est installé dans un rack, il est conseillé de laisser 1 espace libre au-dessus et en dessous de l'amplificateur. Si plusieurs amplificateurs sont installés dans un rack, il est recommandé d'installer les ventilateurs .

Le débit d'air pour le refroidissement de l'AMC 120 P se fait par convection de bas en haut. Le débit d'air pour le refroidissement de l'AMC 250 P est effectué par le ventilateur de l'avant vers l'arrière.

Débranchez les câbles et les sources d'alimentation de l'amplificateur avant de le monter dans le rack.

Veillez installer l'amplificateur à l'intérieur du rack de telle sorte que l'appareil soit stable afin d'éviter une chute.

Positioné l'amplificateur dans le rack de sorte que les quatre fentes soit alignées avec les trous de montage du rack. Visser l'amplificateur au rack en utilisant quatre vis.



## Direct Output

The output terminal strip accepts wire sizes from 16-22AWG (1.5mm<sup>2</sup> – 0.35mm<sup>2</sup>) or spade lugs. The following table should be used as a guideline for cable sizes. Regulations in your area may require different gauged wire and should be checked before using.

OUTPUT	DISTANCE	WIRE SIZE			
		AMC+30	AMC+60	AMC+120	AMC+250
100V	Up to 50m	AWG26(0.12mm <sup>2</sup> )	AWG26(0.12mm <sup>2</sup> )	AWG24(0.2mm <sup>2</sup> )	AWG22(0.35mm <sup>2</sup> )
	50m–200m	AWG24(0.2mm <sup>2</sup> )	AWG20(0.5mm <sup>2</sup> )	AWG18(0.75mm <sup>2</sup> )	AWG16(1.5mm <sup>2</sup> )
	Over 200m	AWG20(0.5mm <sup>2</sup> )	AWG18(0.75mm <sup>2</sup> )	AWG16(1.5mm <sup>2</sup> )	AWG13(2.5mm <sup>2</sup> )
70V	Up to 50m	AWG26(0.12mm <sup>2</sup> )	AWG24(0.2mm <sup>2</sup> )	AWG22(0.35mm <sup>2</sup> )	AWG18(0.75mm <sup>2</sup> )
	50m–200m	AWG20(0.5mm <sup>2</sup> )	AWG18(0.75mm <sup>2</sup> )	AWG16(1.5mm <sup>2</sup> )	AWG13(2.5mm <sup>2</sup> )
	Over 200m	AWG18(0.75mm <sup>2</sup> )	AWG16(1.5mm <sup>2</sup> )	AWG13(2.5mm <sup>2</sup> )	AWG10(6.0mm <sup>2</sup> )
4 ohm	Up to 10m	AWG18(0.75mm <sup>2</sup> )	AWG18(0.75mm <sup>2</sup> )	AWG18(0.75mm <sup>2</sup> )	AWG18(0.75mm <sup>2</sup> )
	10m–30m	AWG13(2.5mm <sup>2</sup> )	AWG13(2.5mm <sup>2</sup> )	AWG13(2.5mm <sup>2</sup> )	AWG13(0.35mm <sup>2</sup> )
	Over 30m	Not Recommended	Not Recommended	Not Recommended	Not Recommended

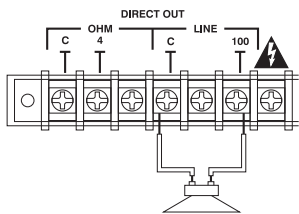

100V Line

minimum total speaker impedance  
 AMC+30 AMC+60 AMC+120 AMC+250  
 333ohm 166ohm 83ohm 40ohm

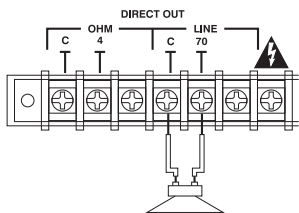

70V Line

minimum total speaker impedance  
 AMC+30 AMC+60 AMC+120 AMC+250  
 166ohm 83ohm 41ohm 20ohm

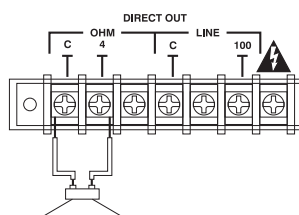

4 ohm voice-coil

minimum total speaker impedance  
 All models  
 4 ohm

**NOTE:** Only connect one output – either Distributed Line or Low Impedance.

## Line Output

The LINE output XLR can be used to connect up to 6 booster amplifiers. Balanced wiring (shielded pair cable) is recommended.

**NOTE:** When wiring the LINE output as unbalanced, Pin2 should be wired as hot and Pin1 should be wired as ground/shield. Do not wire Pin3.

## REC Output

The REC output wiring should be kept as short as possible.

## Input Connections

For wiring balanced in, pin 2 is hot. Unbalanced wiring on the microphone inputs is not recommended. Balanced input wiring (shielded pair cable) is recommended. Unbalanced RCA wiring should be kept as short as possible.

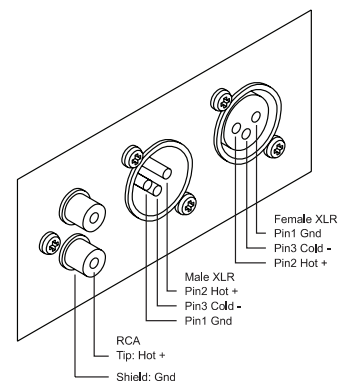



## TROUBLESHOOTING

<b>TROUBLESHOOTING GUIDE</b>		
<b>Trouble</b>	<b>Likely Cause</b>	<b>Remedy</b>
Power LED not on	Power not reaching amplifier	Check power switch is on Check mains connection Check mains fuse
Distorted sound	Output is short circuit Input is overloaded Output is being over driven Bass control is turned up	Check speaker loads for shorts Reduce input level at source Reduce volume levels on front panel Reduce Bass control level
No sound but amp is on	Volume controls down Amplifier has overheated (AMC+60, AMC+120 AMC+250 only) DC fuse(s) blown	Check volume controls Check for obstructions above and below Make sure the amplifier is well ventilated Refer product to local Australian Monitor dealer
No sound from channels 2 and 3	Priority function is being used	Remove signal (disconnect input) from channel 1 OR Disable priority function (see Internal Adjustments)
Tones do not sound when triggered	Tone generator module not installed	Purchase optional Tone generator module



# BLOCK DIAGRAM

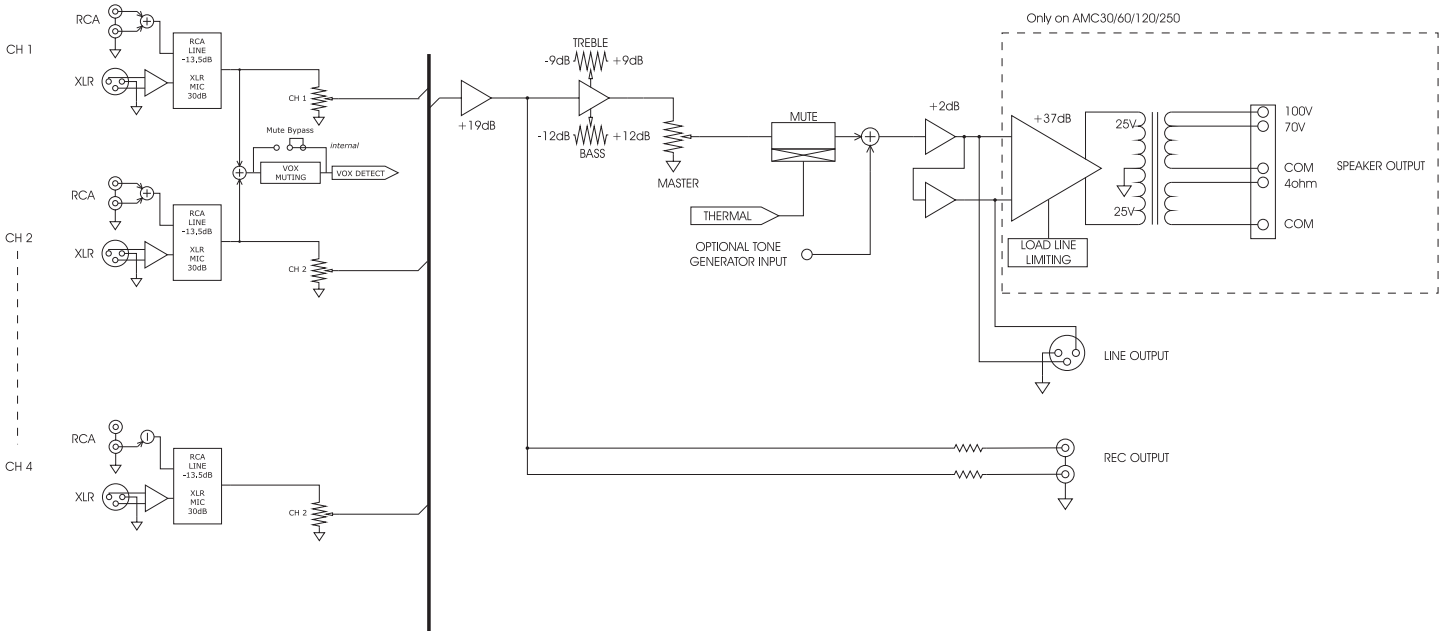



# FUNCTIONAL NOTES AND INTERNAL ADJUSTMENTS

## Priority

Channel 1 will mute channels 2, 3 and 4. This will only occur when signal appears on channel 1, irrespective of the channel volume control.

Priority can be disabled. (See below). The release time is approx. 3 secs and is NOT adjustable. The mute depth is approx. 40dB and is not adjustable.

Use spare terminals for trigger points when using Optional Tone Module

Location of Priority connector (shipped enabled)

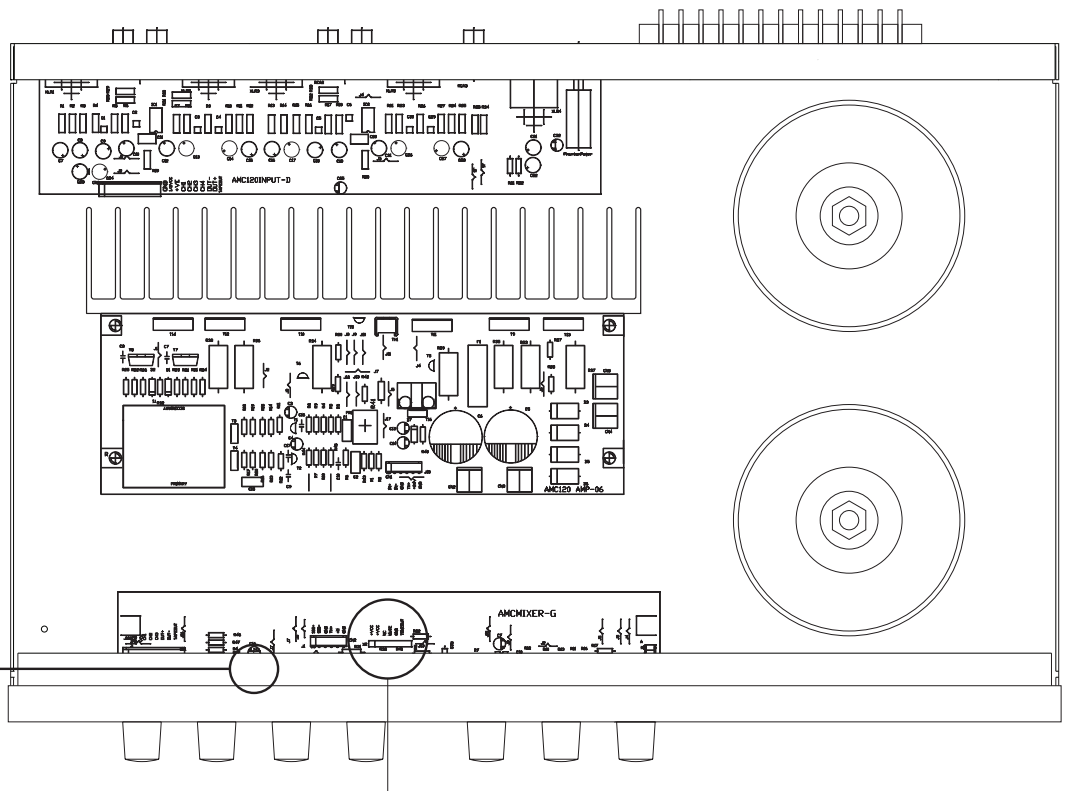
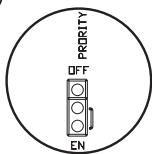

Connector for Optional Tone Module  
Red wire to pin1 left

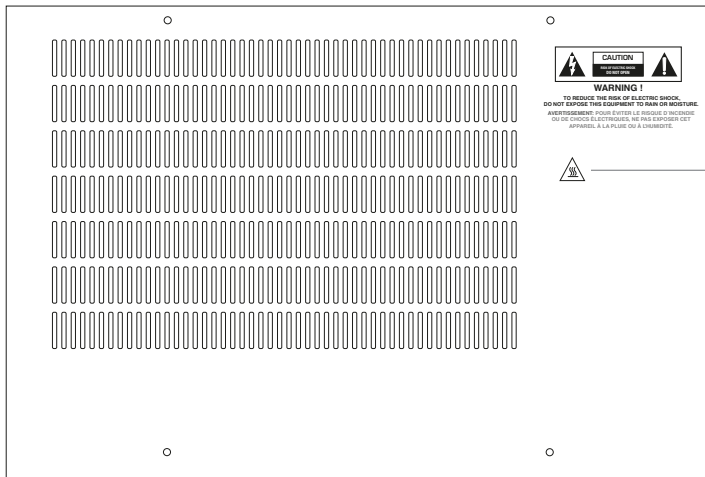

**HOT SURFACE!  
DON'T TOUCH HERE!**

**AMC+120  
AMC+250**

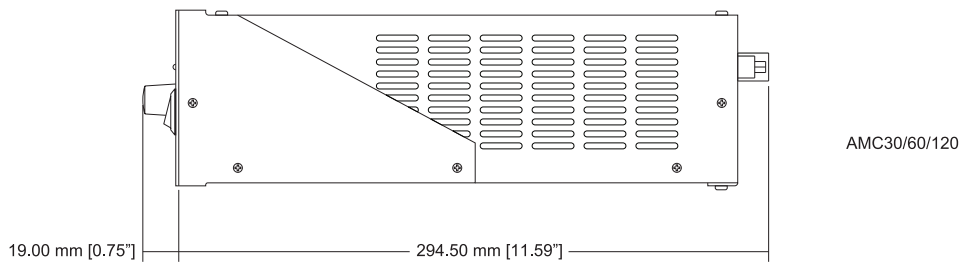
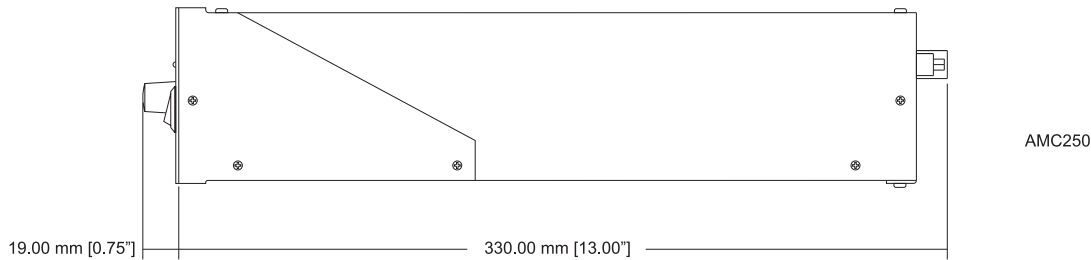
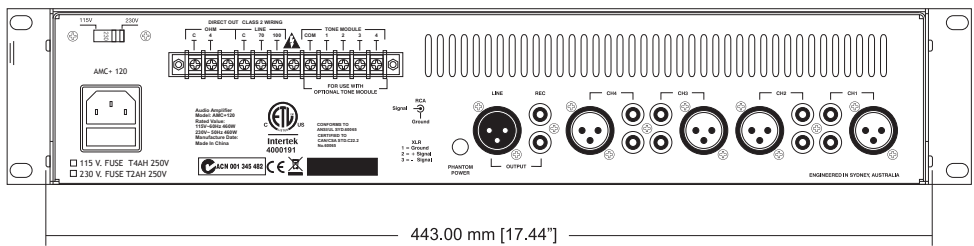
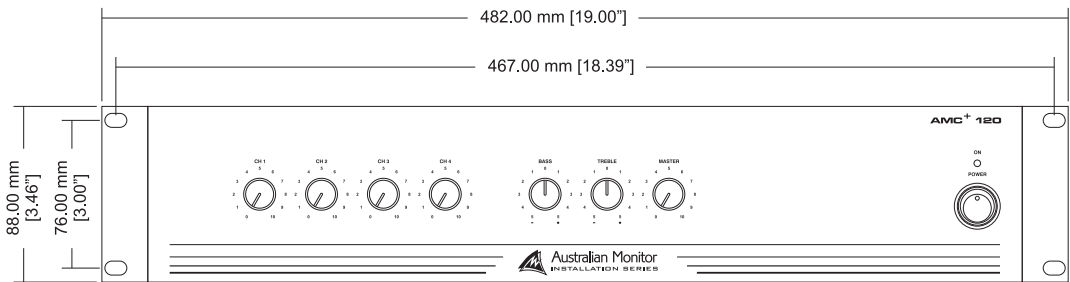



# SPECIFICATIONS

	<b>AMC+ 30</b>	<b>AMC+ 60</b>	<b>AMC+ 120</b>	<b>AMC+ 250</b>
<b>Power Output (0.5%Thd, 1kHz)</b>	30W	60W	120W	250W
<b>S/N Ratio</b>	> 75dB	> 75dB	> 80dB	>85dB
<b>Power Bandwidth (-3db +1db)</b>	85Hz-18kHz	75Hz-20kHz	70Hz-20kHz	40Hz-20kHz
<b>Fuses</b>				
MAINS (115V)	1.0A	3.15A	4A	8A
MAINS (230)	0.5A	1.6A	2A	4A
DC	1.6A (x2)	4A	8A	10A (x2)
<b>Output Regulation</b>	96%	93%	93%	90%
<b>Size (WxHxD)</b>	482 x 88 x 190mm 19" x 3.5" x 7.5"	482 x 88 x 281mm 19" x 3.5" x 11.1"	482 x 88 x 281mm 19" x 3.5" x 11.1"	482 x 88 x 384mm 19" x 3.5" x 15.1"
<b>Net Weight</b>	6.7kg 14.7lb	7.8kg 17.1lb	9.2kg 20.3lb	11.5kg 25.3lb
<b>Shipping Weight</b>	8.7kg 19.2lb	9.8kg 21.5lb	11.3kg 24.8lb	14kg 30.8lb
<b>Shipping Dimensions (WxHxD)</b>	547 x 200 x 400mm 21.5" x 7.9" x 15.7"	547 x 200 x 400mm 21.5" x 7.9" x 15.7"	547 x 200 x 400mm 21.5" x 7.9" x 15.7"	547 x 200 x 415mm 21.5" x 7.9" x 16.3"
<b>Mains Current Draw (230V)</b>				
FULL POWER	0.35A	0.66A	1.20A	2.53A
1/3 POWER	0.23A	0.44A	0.80A	1.61A
1/8 POWER	0.17A	0.32A	0.55A	1.10
IDLE	0.08A	0.13A	0.15A	0.15A
<b>Mains Current Draw (115V)</b>				
FULL POWER	0.73A	1.38A	2.50A	5.28A
1/3 POWER	0.48A	0.92A	1.67A	3.36A
1/8 POWER	0.35A	0.67A	1.15A	2.30A
IDLE	0.17A	0.27A	0.31A	0.31A
<b>Thermal Output (W)</b>				
FULL POWER	38W	67W	128W	259W
1/3 POWER	33W	63W	118W	231W
1/8 POWER	26W	51W	91W	168W
IDLE	11W	19W	26W	26W
<b>Thermal Output (Btu/Hr)</b>				
FULL POWER	130	229	437	884
1/3 POWER	113	215	403	788
1/8 POWER	90	172	311	573
IDLE	38	65	89	89

*\*1/3 and 1/8 power levels relate to voltage changes, not load changes.*

**COMMON TO ALL MODELS**

---

**Thd (1kHz, -1db)**

 Better than 0.5%
 

---

**Mic Input**

 SENSITIVITY  
 IMPEDANCE  
 HEADROOM

 1mV @ 200ohm  
 1k3 ohm  
 77mV (37dB)
 

---

**Aux Input**

 SENSITIVITY  
 IMPEDANCE  
 HEADROOM

 150mV  
 >200kohm  
 > 15V (>40dB)
 

---

**Tone Control**

 BASS @ 100HZ  
 TREBLE @ 10KHZ

 +/- 12 dB  
 +/- 9 dB
 

---

**Line Out**

 NOMINAL OUTPUT  
 OUTPUT IMPEDANCE

 0.775V @ 1kohm  
 100ohm
 

---

**Rec Out**

 NOMINAL OUTPUT  
 OUTPUT IMPEDANCE

 250mV @ 10kohm  
 1kohm
 

---





Lined writing area consisting of 23 horizontal lines.



ENGINEERED BY AUSTRALIAN MONITOR

Address: 1 Clyde Street, Silverwater, Sydney NSW 2128 Australia. Private Bag 149, Silverwater NSW 1811 ABN 78 001 345 482

Website: [www.australianmonitor.com.au](http://www.australianmonitor.com.au) International enquiries email: [international@australianmonitor.com.au](mailto:international@australianmonitor.com.au)



DISTRIBUTED IN AUSTRALIA AND NEW ZEALAND BY HILLS SVL [www.hillssvl.com.au](http://www.hillssvl.com.au)

NSW	QLD	ACT	WA	VIC	SA	NZ
P: 02 9647 1411	P: 07 3852 1312	P: 02 6260 4544	P: 08 9204 0200	P: 03 9890 7477	P: 08 8408 8300	P: 09 415 9426
E: <a href="mailto:nsw@hillssvl.com.au">nsw@hillssvl.com.au</a>	E: <a href="mailto:qld@hillssvl.com.au">qld@hillssvl.com.au</a>	E: <a href="mailto:act@hillssvl.com.au">act@hillssvl.com.au</a>	E: <a href="mailto:wa@hillssvl.com.au">wa@hillssvl.com.au</a>	E: <a href="mailto:vic@hillssvl.com.au">vic@hillssvl.com.au</a>	E: <a href="mailto:sa@hillssvl.com.au">sa@hillssvl.com.au</a>	E: <a href="mailto:sales@hillssvl.co.nz">sales@hillssvl.co.nz</a>